

## TPWX2GD

### TPWX2GD "HAZARDOUS ZONE" SERIES PALLET TRUCK SCALE ATEX



**ORIENTABLE**



Pallet truck scales, with built-in electronic weighing, for dangerous areas classified as hazardous (ZONES 1 and 21 & 2 and 22) in accordance with Ex II 2GD IIB T4 T197°C X. The ATEX certified four load cell weight detection IP68 guarantees the best accuracy in all work conditions. Available also CE-M APPROVED.

Working in cooperation with:

**CBH VAEGTE APS**

VONSILDVEJ 207 - 6000 - KOLDING  
Tel. 004575567310 Fax. 004575567320  
info@cbh-vaegte.dk

The best solution  
for advanced industrial  
applications

## MAIN FEATURES

- Maximum lifting capacity: 2500 kg.
- Accuracy: +/- 0.05% of the maximum capacity.
- Fork dimensions 1150 x 550 x 85 mm.
- Weighs about 125 kg.
- Bearing structure in extra thick sheet steel and oven-fire painted interior construction.
- Standard fitted with +/-160° swivelling column head.
- Steering wheels and double loading rollers with a poliurethane coating.
- Atex certified, 4 stainless steel IP68 shear-beam load cells.
- Indicator with easy to clean satined stainless steel case with IP68 enclosure built to withstand humid and dusty environments; large LCD display 25-mm high contrast digits which are clearly visible even in poor lighting conditions; 17-key numerical/functional membrane waterproof keyboard.
- Calibration and Set-Up parameters configurable from keyboard.
- Power supply through extractable battery, rechargeable in safe zone.
- 150-hour approximate operating time.
- Equipped with 230Vac 50 Hz battery charger to be recharged in a safe area.

## MAIN FUNCTIONS

- Zeroing, Tare
- High Resolution Weighing x 10
- Net/Gross or lb/kg conversion
- Weighs accumulation
- Formulation
- Counting
- Hold

## AVAILABLE UPON PRICE ESTIMATE

- 680 mm fork width.
- Special fork length from 850 to 1500 mm.
- Special capacity e/o divisions.
- High resolution.

## DETAIL 1

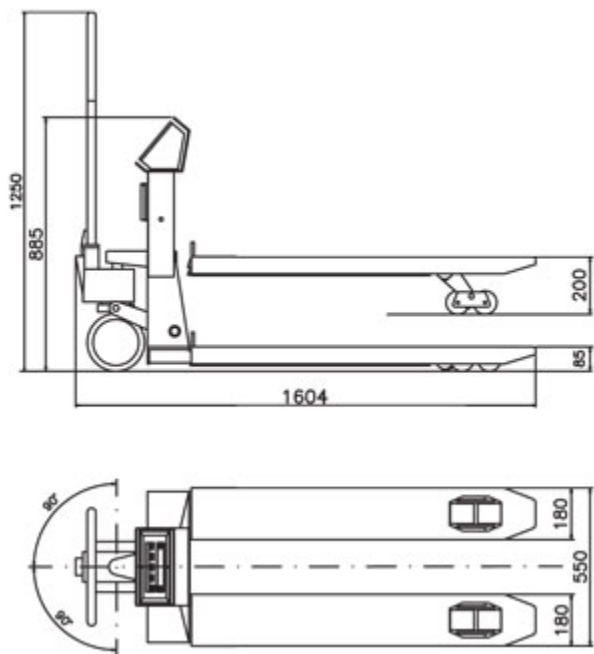

Dimensions in mm.

## VERSIONS

### Versioni disponibili

Codice	Max (kg)	d (kg)	<b>M</b> (kg)	d HR (kg) *
TPWX2GD20-1	500/1000/2000	0,2/0,5/1	--	0,1/0,2/0,5
TPWX2GD20M-1 <b>M</b>	1000/2000	--	0,5/1	--
TPWX2GD25-1	600/1500/2500	0,2/0,5/1	--	0,1/0,2/0,5
TPWX2GD25M-1 <b>M</b>	1500/2500	--	0,5/1	--
TPWX2GD15M-1 <b>M</b>	600/1500	--	0,2/0,5	--

(\*) Divisione HR disponibile con la relativa opzione EHR.



www.diniargeo.com



“YOUR WORLDWIDE PARTNER FOR WEIGHING,”

DINI ARGEO  
FRANCE sarl  
Nogent-sur-Marne

DINI ARGEO  
GMBH  
Sinsheim - Germany

DINI ARGEO  
UK Ltd  
Taunton - United Kingdom

DINI ARGEO WEIGHING  
INSTRUMENTS Ltd  
Shanghai - China

DINI ARGEO  
WEIGHBRIDGES  
Calto (RO) – Italy



HEAD OFFICE  
Via Della Fisica, 20  
41042 Spezzano di Fiorano Modena - Italy



**CBH VAEGTE APS**

VONSILDVEJ 207 - 6000 - KOLDING

Tel. 004575567310 Fax. 004575567320

info@cbh-vaegte.dk

SALES AND TECHNICAL ASSISTANCE SERVICE